

ATNS

Advanced Telecommunications Network Systems

7 Whitelawn Avenue • Milton, MA 02186

(617) 553-0778

Ed Alvera
WFXT
Needham, MA

March 18, 1992

Dear Ed,

Enclosed is the proposal for both the 3.8-meter and 5.0-meter receiver-only dishes.

The price, as proposed, includes all the labor, hardware and equipment necessary to remove the dishes from the Needham site, transport to the Dedham site, install mounting bolts for the dishes, fabricate and galvanize a 5" OD mast and mounting flange for the 3.8-meter dish, lift dishes to the roof, bolt in place and perform orientation for both the 5- and 3.8-meter dish.

As you had mentioned to me on Thursday, March 12, 1992, you could not move both dishes at once. To accomplish this, I propose to move the 5-meter dish first, in order to use the mount as a drilling template, and bolt in place both the 5-meter dish and the fabricated mount for the 3.8-meter dish. This would put the 5-meter dish in service at the Dedham site, enabling us to move the 3.8-meter dish intact on the trailer to which it is currently mounted. This plan would ensure the use of one satellite receiver at both sites, ending with both receiver dishes installed at the Dedham site.

I have also included some explanatory drawings. If there are any questions, please feel free to call.

Sincerely,

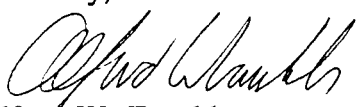
Alfred W. Trenkler
Director of Engineering

PROPOSAL

Advanced Telecommunications Network Systems, hereafter ATNS, proposes to provide all the equipment and labor necessary to complete the relocation of a 3.8- and 5.0-meter receive dish in a manner specified in the attached drawings and specifications and as itemized below:

1. Removal of 3.8- and 5.0-meter receive dish(es)
2. Provision of drilling equipment
3. Provision of mounting bolts
4. Provision of concrete for mounting bolts
5. Provision of crane for removal and installation of dish(es)
6. Provision of all necessary labor
7. Orientation of both dishes
8. Provide, fabricate and hot-dip-galvanize mounting pipe and flange assembly for 3.8-meter dish mount
9. Provision of flatbed truck for transport of 5-meter dish
10. Provision of vehicle to tow 3.8-meter dish trailer to Dedham

The total price for this project is \$9,987.00, with the proposed payment schedule as follows:

55% upon signing of contract	\$5,492.85
22.5% upon completion	2,247.08
22.5% net 15 days upon completion	<u>2,247.07</u>
	\$9,987.00

PIPE MOUNT FOR 3.8 METER RECEIVE DISH

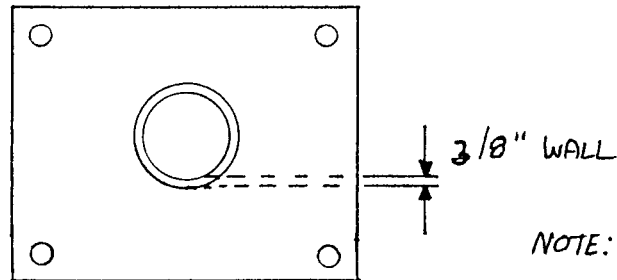
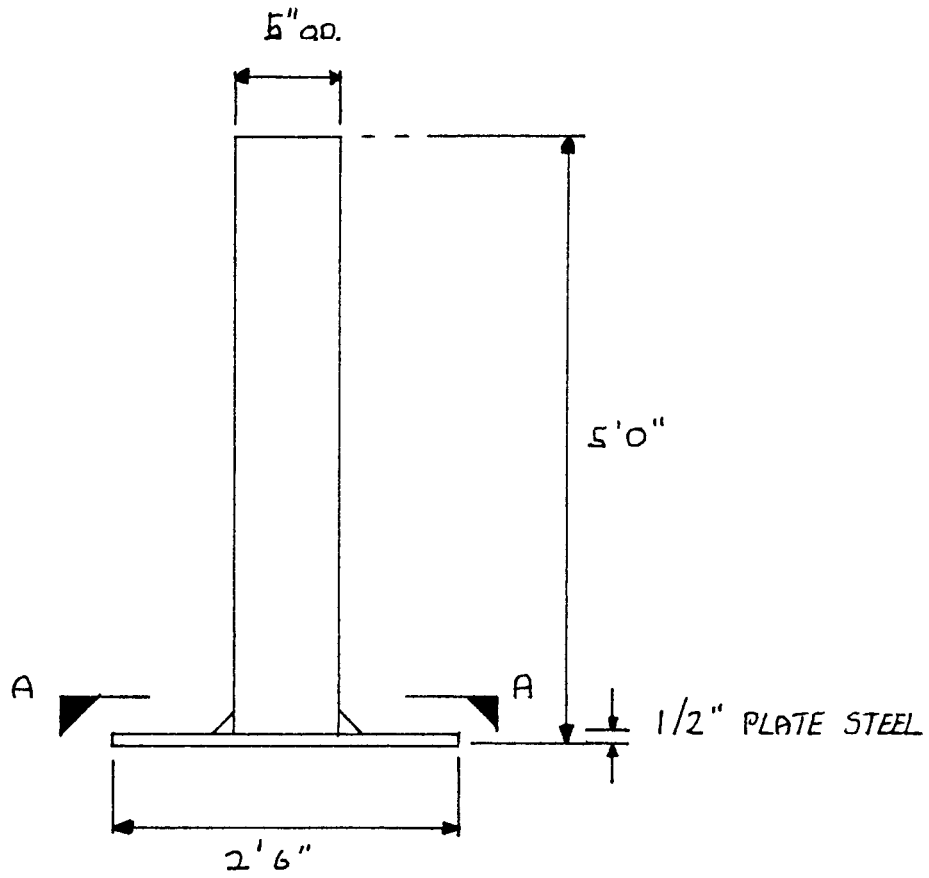

SECTION "A-A"

NOTE:

1. WELDMENT PER ANSI/AWS D1.1
2. US OR CANADIAN STEEL ONLY
3. HOT DIP GALVANIZE PER ASTM A123, A143, A153, A384, A385 AND A780

TYPICAL MOUNTING BOLT FOR 3.8 AND 5.0 METER DISH

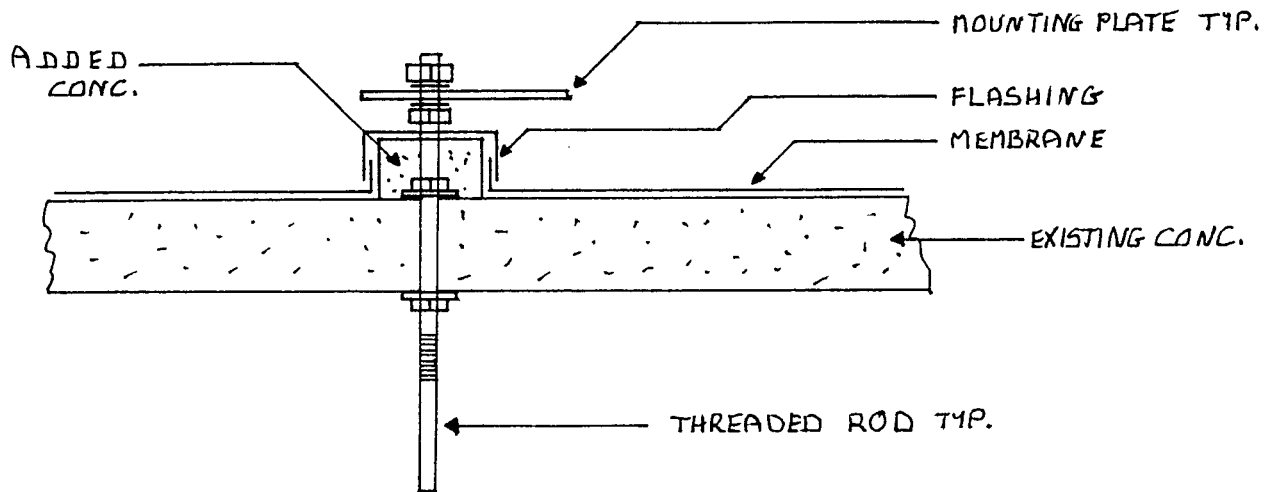

NOTE

1. ADDED CONCRETE TO BE 3000 PSI @ 28 DAYS
2. THREADED ROD TO BE CERTIFIED US OR CANADIAN STEEL
3. ALUMINUM ROOF DECKING NOT SHOWN

ATNS

Advanced Telecommunications Network Systems
7 Whitelawn Avenue • Milton, MA 02186
(617) 553-0778

FAX COVER SHEET

date: 18 MARCH 92

to: ED ALVERA

company: WFXT - NEEDHAM

fax #: 455 8768

from: AL TRENKLER

pages: 8
(including cover)

Comments: PLEASE CALL ME IF YOU DID NOT
RECEIVE ALL EIGHT (8) PAGES

FAX: (617) 770-9991